

UDX-GT9

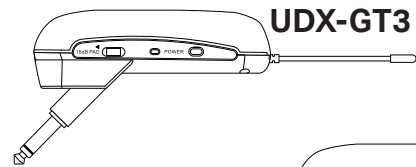

UDX-GT3

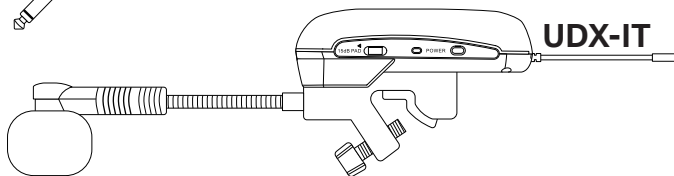

UDX-IT

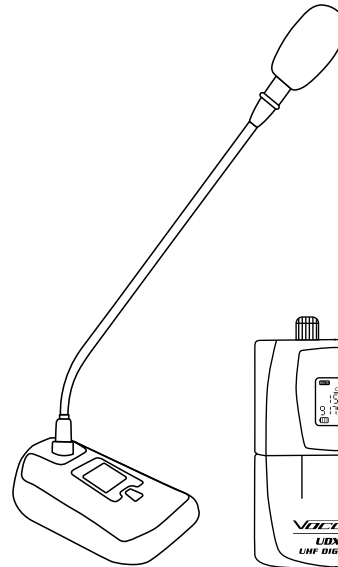

UDX-CF

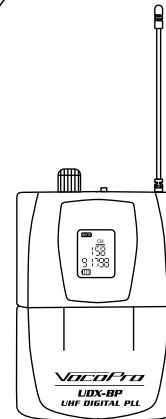

UDX-BP

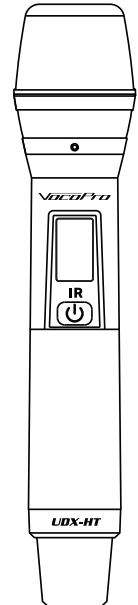

UDX-HT



PROFESSIONAL DUAL UHF DIGITAL PLL MICROPHONE SYSTEM

VocoPro | UDX-DUAL

POWER

CHANNEL 1-2

UDX-DUAL

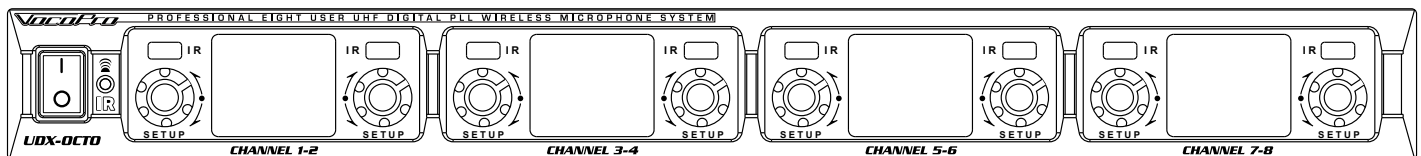

UDX-OCTO

CHANNEL 1-2

CHANNEL 3-4

CHANNEL 5-6

CHANNEL 7-8

Receivers and Transmitters Sold Separately

UDX-OCTO

UDX Series

UHF Digital PLL Wireless Microphone System
with "Mic-on-Chip" Technology
Manual for all UDX receivers and Transmitters

OWNER'S MANUAL

WELCOME

And thank you for purchasing UDX Series from VocoPro. Along with quality products our commitment to customer satisfaction means we have technical support professionals ready to assist you. Be sure to visit our website- www.vocopro.com for the latest information on new products.



We are at:

VocoPro
1728 Curtiss Court
La Verne, CA 91750



Phone:

Toll Free: 800-678-5348
TEL: 909-593-8893
FAX: 909-593-8890



Tech Support:

techsupport@vocopro.com

Customer Service:

info@vocopro.com

Legal Disclaimer

All rights reserved. Information, specifications, diagrams, images, and instructions herein are subject to change without notice. VocoPro Products, logo and identifying product names and numbers herein are trademarks of VocoPro. Copyright protection claimed includes all forms and matters of copyrightable materials and information now allowed by statutory or judicial law or hereinafter granted. Product names used in this document may be trademarks or registered trademarks of their respective companies and are hereby acknowledged. All non-VocoPro Products, brands and product names are trademarks or registered trademarks of their respective companies.

VocoPro hereby disclaims any and all liabilities for property, equipment, building, and electrical damages, injuries to any persons, and direct or indirect economic loss associated with the use or reliance of any information contained within this document, and/or as a result of the improper, unsafe, insufficient and negligent assembly, installation, rigging, and operation of this product.

Please record the model number and serial number below, for easy reference, in case of loss or theft. These numbers are located on the packaging the item came in. Space is also provided for other relevant information.

This is not considered a receipt. Please keep a copy of your purchase receipt, provided by the dealer, in your records. A receipt is required for all warranty work.

Model Number

Serial Number

Date of Purchase

Place of Purchase

Listening for a Lifetime

Selecting fine audio equipment such as the unit you've just purchased is only the start of your musical enjoyment. Now it's time to consider how you can maximize the fun and excitement your equipment offers. VocoPro and the Electronic Industries Association's Consumer Electronics Group want you to get the most out of your equipment by playing it at a safe level. One that lets the sound come through loud and clear without annoying blaring or distortion and, most importantly, without affecting your sensitive hearing.

Sound can be deceiving. Over time your hearing "comfort level" adapts to a higher volume of sound. So what sounds "normal" can actually be loud and harmful to your hearing. Guard against this by setting your equipment at a safe level BEFORE your hearing adapts.

To establish a safe level:

- Start your volume control at a low setting.
- Slowly increase the sound until you can hear it comfortably and clearly, and without distortion.

Once you have established a comfortable sound level:

- Set the dial and leave it there.
- Pay attention to the different levels in various recordings.

Taking a minute to do this now will help to prevent hearing damage or loss in the future. After all, we want you listening for a lifetime.

Used wisely, your new sound equipment will provide a lifetime of fun and enjoyment. Since hearing damage from loud noise is often undetectable until it is too late, this manufacturer and the Electronic Industries Association's Consumer Electronics Group recommend you avoid prolonged exposure to excessive noise. This list of sound levels is included for your protection.

Level	Example
30	Quiet library, Soft whispers
40	Living room, Refrigerator, Bedroom away from traffic
50	Light traffic, Normal Conversation
60	Air Conditioner at 20 ft., Sewing machine
70	Vacuum cleaner, Hair dryer, Noisy Restaurant
80	Average city traffic, Garbage disposals, Alarm clock at 2 ft.

The following noises can be dangerous under constant exposure:

Level	Example
90	Subway, Motorcycle, Truck traffic, Lawn Mower
100	Garbage truck, Chainsaw, Pneumatics drill
120	Rock band concert in front of speakers
140	Gunshot blast, Jet plane
180	Rocket launching pad

-Information courtesy of the Deafness Research Foundation

Safety Instructions



CAUTION RISK OF SHOCK



CAUTION: To reduce the risk of electric shock, do not remove cover (or back). No user-serviceable parts inside. Only refer servicing to qualified service personnel.

Explanation of Graphical Symbols



The lightning flash & arrowhead symbol, within an equilateral triangle, is intended to alert you to the presence of danger.



The exclamation point within an equilateral triangle is intended to alert you to the presence of important operating and servicing instructions.

WARNING: To reduce the risk of fire or electric shock, do not expose this unit to rain or moisture.

1. Read Instructions - All the safety and operating instructions should be read before the appliance is operated.
2. Retain Instructions - The safety and operating instructions should be retained for future reference.
3. Heed Warnings - All warnings on the appliance and in the operating instructions should be adhered to.
4. Follow Instructions - All operating and use instructions should be followed.
5. Attachments - Do not use attachments not recommended by the product manufacturer as they may cause hazards.
6. Water and Moisture - Do not use this unit near water. For example, near a bathtub or in a wet basement and the like.
7. Carts and Stands - The appliance should be used only with a cart or stand that is recommended by the manufacturer.
 - 7 A. An appliance and cart combination should be moved with care. Quick stops, excessive force, and uneven surfaces may cause an overturn.
8. Ventilation - The appliance should be situated so its location does not interfere with its proper ventilation. For example, the appliance should not be situated on a bed, sofa, rug, or similar surface that may block the ventilation slots.
9. Heat - The appliance should be situated away from heat sources such as radiators, heat registers, stoves, or other appliances (including amplifiers) that produce heat.



10. Power Sources - The appliance should be connected to a power supply only of the type described in the operating instructions or as marked on the appliance.

11. Grounding or Polarization - Precautions should be taken so that the grounding or polarization means of an appliance is not defeated.

12. Power-Cord Protection - Power-supply cords should be routed so that they are not likely to be walked on or pinched by items placed upon or against them, paying particular attention to cords at plugs, convenience receptacles, and the point where they exit from the appliance.

13. Cleaning - Unplug this unit from the wall outlet before cleaning. Do not use liquid cleaners or aerosol cleaners. Use a damp cloth for cleaning.

14. Power lines - An outdoor antenna should be located away from power lines.

15. Non-use Periods - The power cord of the appliance should be unplugged from the outlet when left unused for a long period of time.

16. Object and Liquid Entry - Care should be taken so that objects do not fall and liquids are not spilled into the enclosure through openings.

17. Damage Requiring Service - The appliance should be serviced by qualified service personnel when:

- A. The power supply cord or plug has been damaged; or
- B. Objects have fallen into the appliance; or
- C. The appliance has been exposed to rain; or
- D. The appliance does not appear to operate normally or exhibits a marked change in performance; or
- E. The appliance has been dropped, or the enclosure damaged.

18. Servicing - The user should not attempt to service the appliance beyond that described in the operating instructions. All other servicing should be referred to qualified service personnel.

Note: To CATV system installer's (U.S.A.): This reminder is provided to call the CATV system installer's attention to Article 820-40 of the NEC that provides guidelines for proper grounding and, in particular, specifies that the cable ground shall be connected as close to the point of cable entry as practical.



This device complies with Part 15 of the FCC rules. Operation is subject to the condition that this device may not cause harmful interference.

FCC license may be required

FCC Information

1. **IMPORTANT NOTICE: DO NOT MODIFY THIS UNIT!**
This product, when installed as indicated in the instructions contained in this manual, meets FCC requirements. Modifications not expressly approved by Vocopro may void your authority, granted by the FCC, to use this product.

2. **IMPORTANT:** When connecting this product to accessories and/or another product use only high quality shielded cables. Cable(s) supplied with this product **MUST** be used. Follow all installation instructions. Failure to follow instructions could void your FCC authorization to use this product in the U.S.A.

3. **NOTE:** This product has been tested and found to comply with the requirements listed in FCC Regulations, Part 15 for Class "B" digital devices. Compliance with these requirements provides a reasonable level of assurances that your use of this product in a residential environment will not result in harmful interference with other electronic devices. This equipment generates/uses radio frequencies and, if not installed and used according to the instructions found in the owner's manual, may cause interference harmful to the operation of other electronic devices. Compliance with FCC regulations does not guarantee that interference will not occur in all installations. If this product is found to be the source of interference, which can be determined by turning the unit "Off" and "On", please try to eliminate the problem by using one of the following measures:

Relocate either this product or the device that is being affected by the interference.

Use power outlets that are on different branch (circuit breaker or fuse) circuits or install AC line filter(s).

In the case of radio or TV interference, relocate/reorient the antenna. If the antenna lead-in is 300-ohm ribbon lead, change the lead-in to coaxial type cable.

If these corrective measures do not produce satisfactory results, please contact your local retailer authorized to distribute Vocopro products. If you can not locate the appropriate retailer, please contact Vocopro, 1728 Curtiss Court, La Verne, CA 91750.

Voltage Selector (General Model Only)

Be sure to position the voltage selector to match the voltage of your local power lines before installing the unit.



CAUTION: The apparatus is not disconnected from the AC power source so long as it is connected to the wall outlet, even if the apparatus itself is turned off. To fully ensure that the apparatus is indeed fully void of residual power, leave unit disconnected from the AC outlet for at least fifteen seconds.

CALIFORNIA PROP 65 WARNING

⚠ WARNING: Cables, Cable Assemblies, and Printed Circuit Boards can expose you to chemicals including lead and lead compounds which are known to the State of California to cause cancer and birth defects or other reproductive harm. For more information, go to www.P65Warnings.ca.gov

Table of Contents

Legal Disclaimer	2
Listening for a Lifetime	3
Safety Instructions	4
FCC Information	5
Table of Contents	6
Functions and Descriptions	7-18
Getting Connected	19-20
Syncing the Transmitters to the Receiver	21-22
Setting the Frequency on the Receiver	23-24
Specifications	25
Troubleshooting	26
Notes	27
LIMITED DOMESTIC WARRANTY	28-30

Functions and Descriptions

UDX-OCTO Receiver (Front)

- 1. Power Switch:** Turns the receiver ON or OFF.
- 2. IR Sensor:** When syncing a transmitter to any channel on the receiver, hold the IR sensor on the transmitter up to this IR sensor on the receiver to sync the frequency and pair the transmitter to a channel on the receiver.
- 3. Channel IR Button:** Hold for 3 seconds to begin pairing for that channel. The IR sensor on the receiver will blink red, indicating that it is ready to pair.
- 4. Channel Setup Knob/Button:** When the channel is locked, turn to adjust the volume output for that channel. Press and hold the button for a couple of seconds to unlock or lock the channel. When the channel is unlocked, press the button to switch between Channel mode and Scan mode, and turn the knob to change the selected frequency.

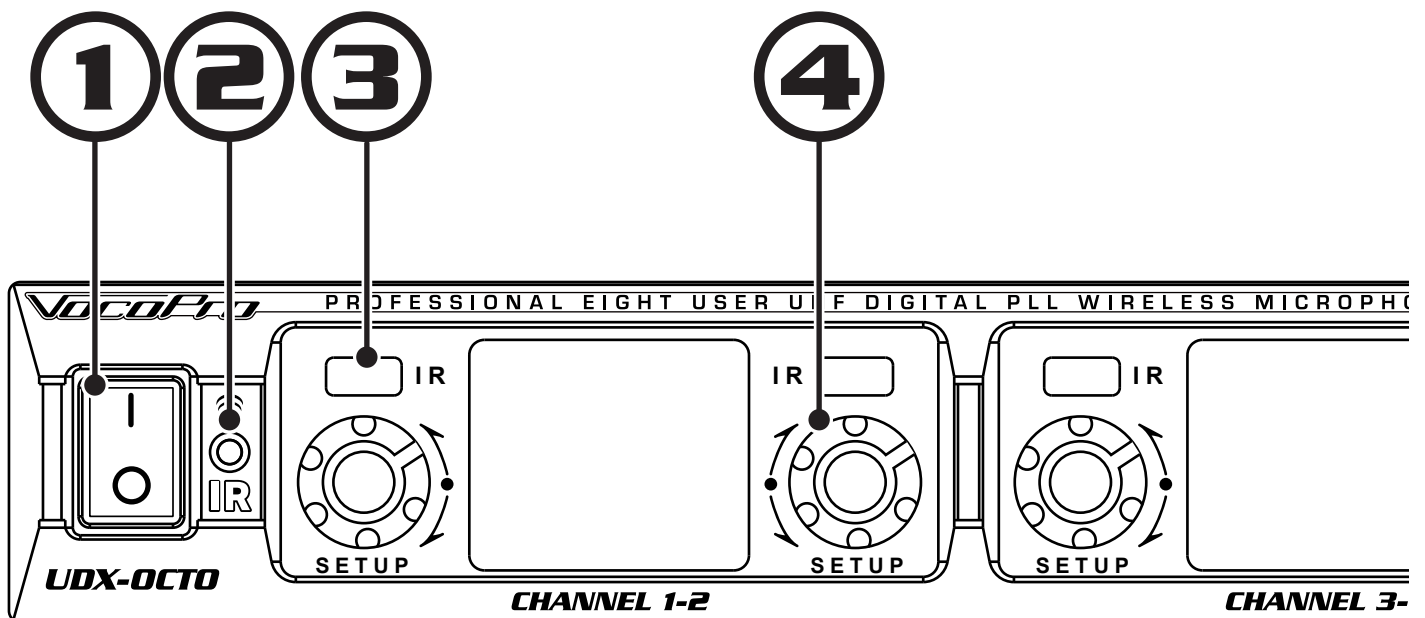

Functions and Descriptions

UDX-OCTO Receiver (Back)

- 1. Antenna Connection Jacks:** Connect the TNC antenna to these jacks.
- 2. Channel 1-8 Balanced Outputs:** Use these output jacks to get each channel audio on separate cables.
- 3. XLR Mix Out:** Connect an XLR-female cable here to get all 8 channels together on a single cable.
- 4. 1/4 Inch Mix Out:** Connect a 1/4 inch cable here to get all 8 channels together on a single cable.
- 5. DC Input:** Connect the power adapter here.

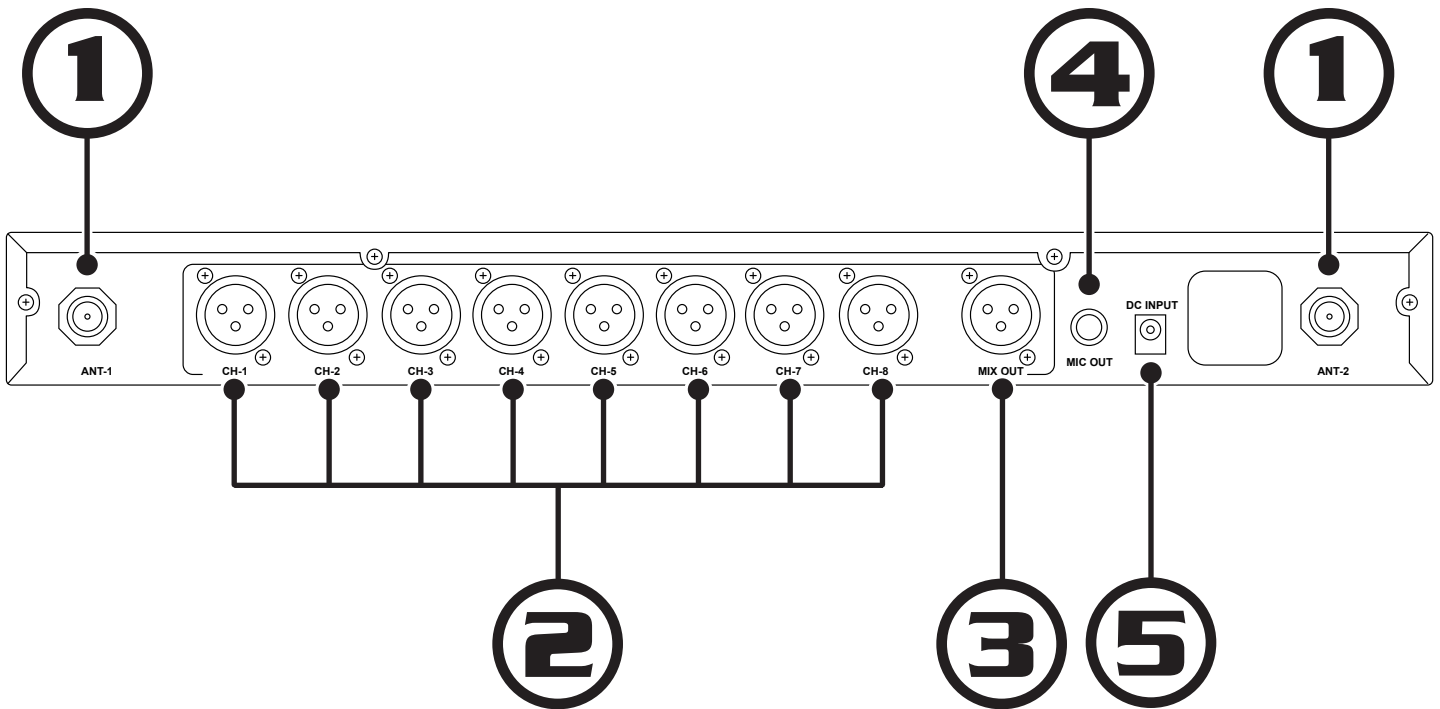

Functions & Descriptions

UDX-DUAL Receiver (Front)

- 1. Power Switch:** Power system ON or OFF.
- 2. IR Sensor:** When syncing a transmitter to any channel on the receiver, hold the transmitter IR sensor up to this IR sensor so that they are facing each other. The frequency will be synced and the transmitter will be paired with the selected channel.
- 3. Channel IR Button:** Press and hold for 3 seconds to initiate pairing mode. The IR Sensor will flash red to indicate that it is ready to pair.
- 4. Channel Setup Knob/Button:** When the channel is locked, turn to adjust the volume output for that channel. When the channel is unlocked, press the button to switch between Channel mode and Scan mode, and turn the knob to change the selected frequency.

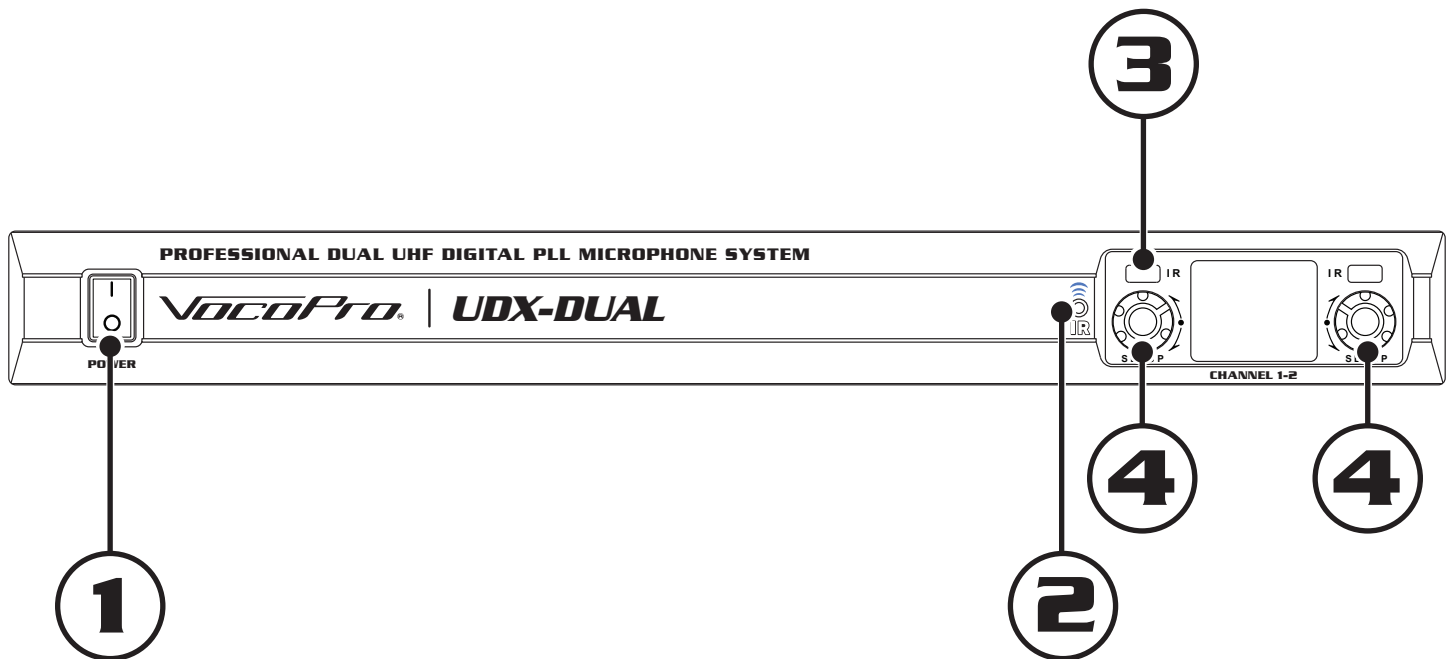

Functions & Descriptions

UDX-DUAL Receiver (Back)

1. **Antenna Connector:** Connect the TNC antenna to these jacks.
2. **Balanced Outputs:** Use these output jacks to get each channel audio on separate cables
3. **Balanced Mix Out:** Connect XLR cable here to get both channels through a single cable.
4. **¼ Inch Mix Out:** Connect a ¼ inch cable here to get both channels together on a single cable..
5. **DC Input:** Connect the power adapter here.

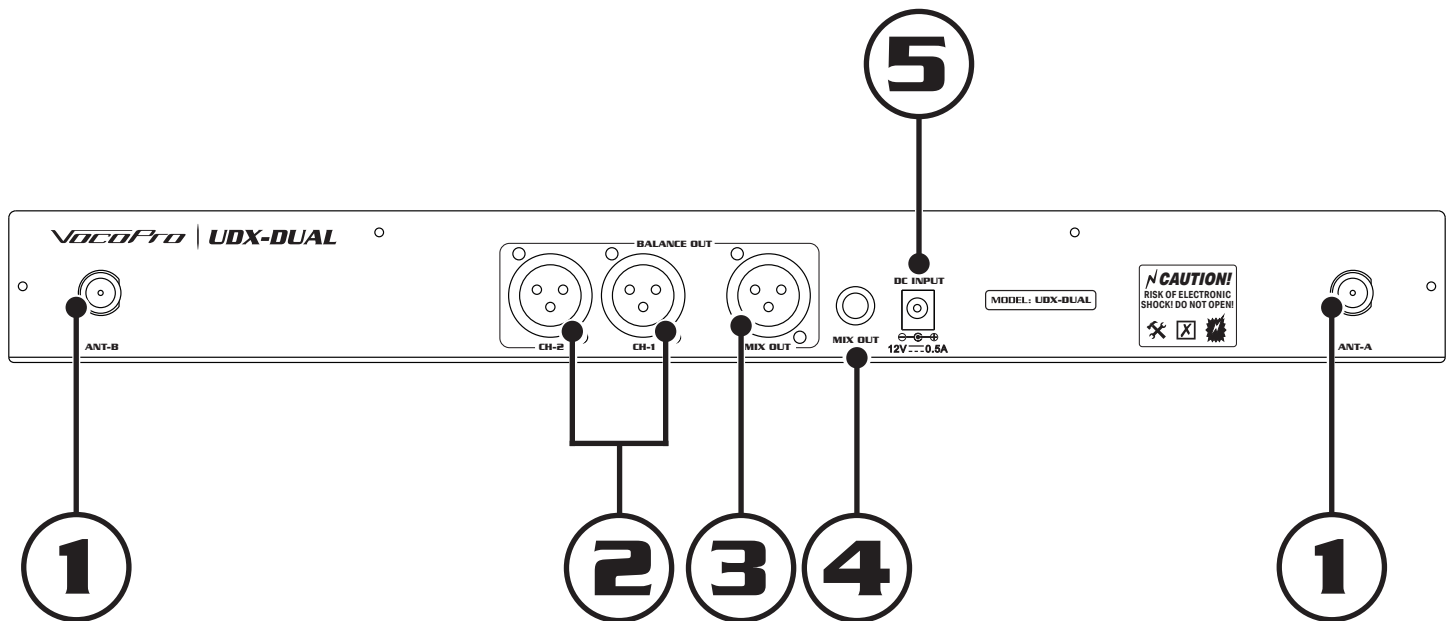

Functions and Descriptions

UDX-OCTO Receiver (Display)

- 1. AF Meter:** Shows the audio signal strength being picked up by the transmitter.
- 2. Lock Icon:** Indicates whether the two channels on that screen are locked or unlocked. When locked, you can adjust the volume or sync to those channels. When unlocked, you can change the frequency by selecting a new channel number or scanning for an open frequency.
- 3. Frequency:** Displays the currently selected frequency in MHz.
- 4. Channel Display:** Shows the currently selected channel number. If you select a frequency by scanning, this will be blank.
- 5. Scan Display:** Shows the relative position of the selected frequency within the available range. EX: For channel 1 you can scan for a frequency between 902 MHz and 905.1 MHz. The closer you move to 905.1 MHz, the further the indicator line will move to the right.
- 6. RF Meter:** Shows the connection strength between the receiver and the transmitter.
- 7. Volume Display:** Shows the volume setting for that channel, from 0% at no volume to 100% at full volume. If the speaker symbol is red with a line through it, that channel is muted, either because the transmitter itself is muted, powered off, or out of range.
- 8. Battery Indicator:** Shows the battery life for the transmitter on that channel.

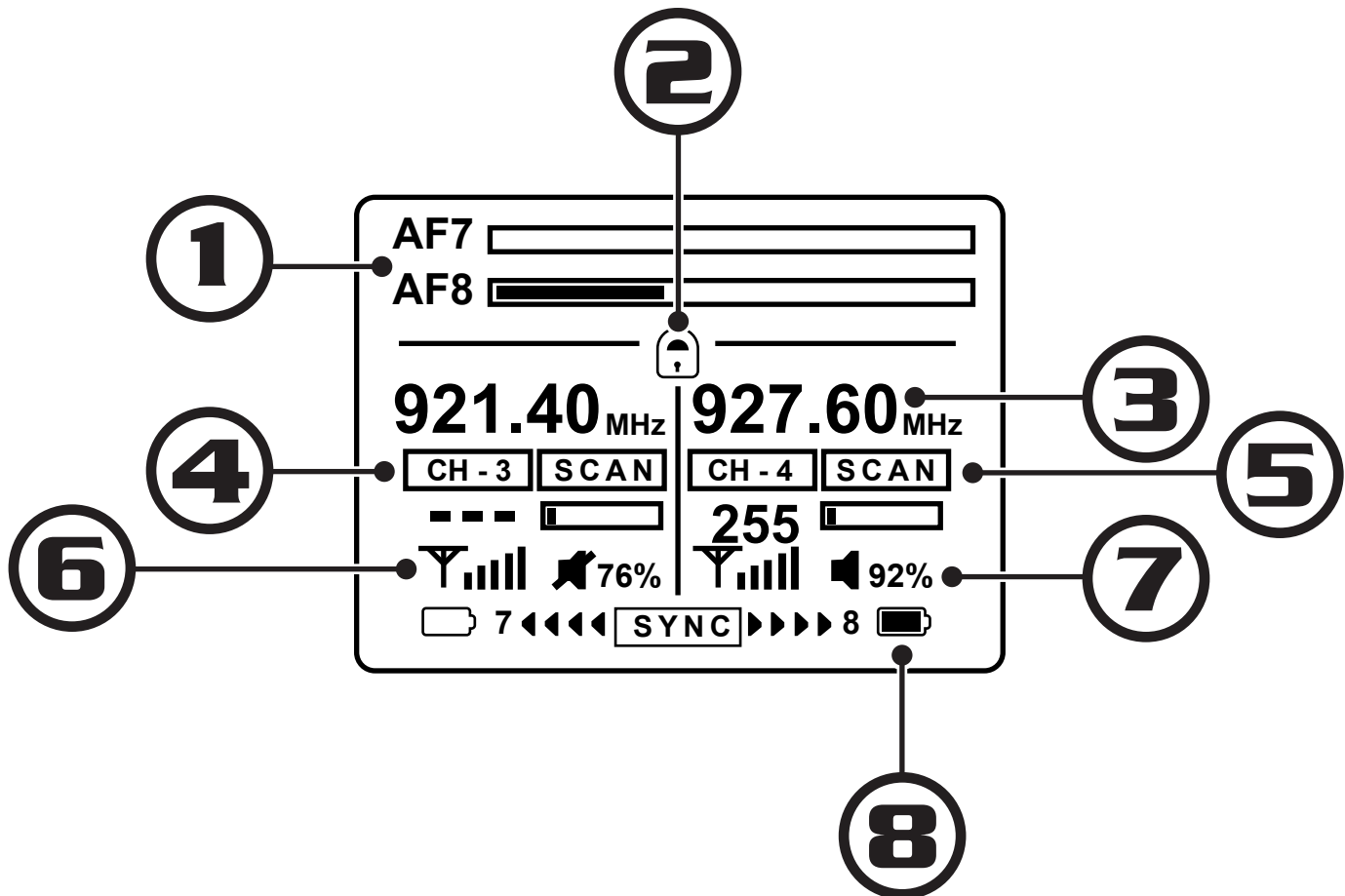

Functions and Descriptions

UDX-HT Handheld Microphone Transmitter

- 1. Microphone Capsule:** Where the microphone picks up the sound. For the best reception, point the top of the microphone directly at the speaker's mouth or other sound source.
- 2. Display & IR Sensor:** The display shows the currently selected frequency and the battery life. It will also display MUTE when the mic is muted.

Note: The IR sensor is also built into the display, so you will want to face the mic display towards the IR sensor on the receiver when syncing the mic.
- 3. Power/Mute Button:** Press to turn the mic on. Press again to mute or unmute the mic. Hold to turn the mic off.
- 4. Battery Compartment:** Unscrew the cover to access the battery compartment. 2x AA 1.5V batteries are required to power the mic.

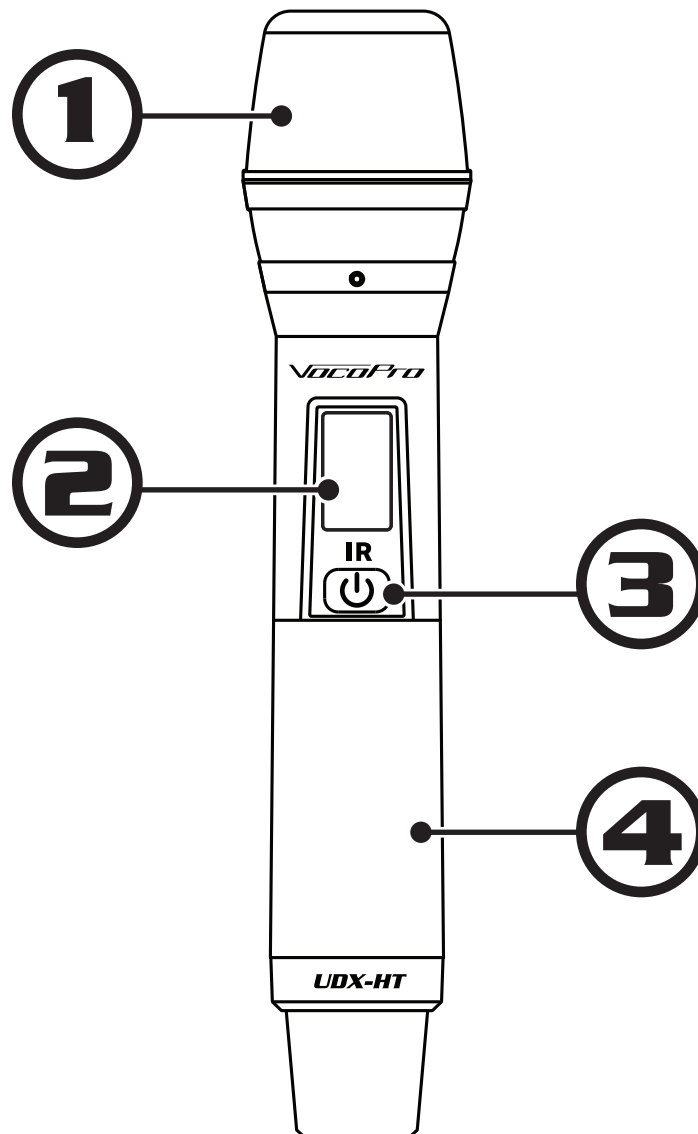

Functions and Descriptions

UDX-BP Bodypack Transmitter

- 1. On/Mute/Off Power Switch:** Use to turn the pack on or off. When the switch is in the middle position the pack will power on but be muted.
- 2. Volume Knob:** Controls the audio level being sent to the receiver. Turn clockwise to increase volume. This control works independently from the volume control on the receiver. It is recommended to turn this up as far as possible without distorting to ensure a strong signal is being sent.
- 3. Mini-XLR Microphone Input:** Connect the included headset microphone here.
- 4. Display:** Shows the currently selected frequency and battery life. It will also show MUTE when the switch is in the middle Mute position.
- 5. IR Sensor:** Open the battery cover to reveal the IR sensor. You will need to point this sensor towards the IR sensor on the receiver when pairing the body pack.
- 6. Battery Compartment:** Open the battery cover to access the battery compartment. 2x AA 1.5V batteries are required to power the body pack.

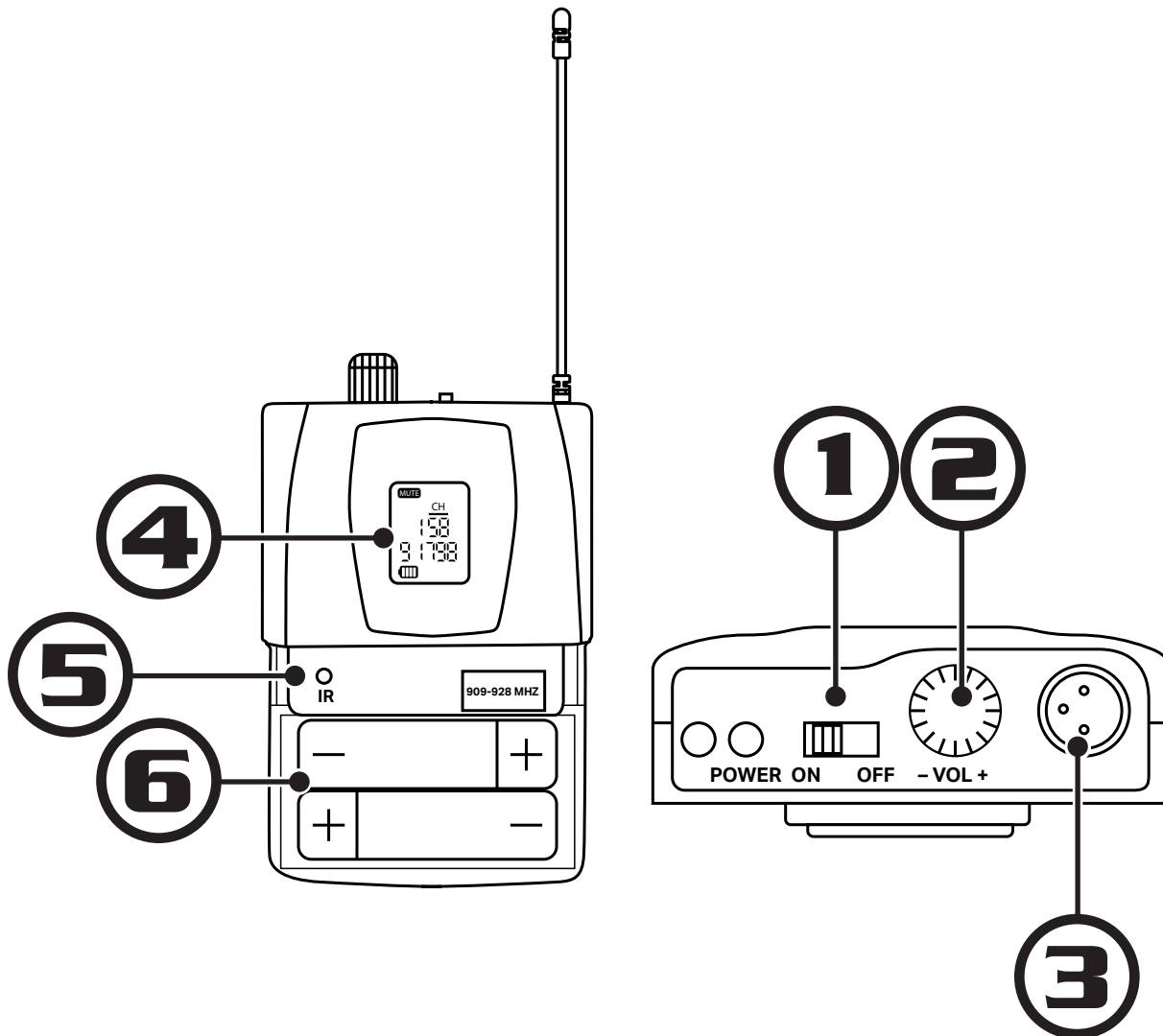

Functions and Descriptions

UDX-CF Conference Style Tabletop Transmitter and Gooseneck Microphone

- 1. Power/Mute Button:** Press to turn the mic on. Press again to mute or unmute the mic. Hold to turn the mic off.
- 2. Display & IR Sensor:** Shows the currently selected frequency and battery life, as well as a speaker symbol to show if the mic is muted or not. It also has an AF meter for the microphone. You want this meter to fill up most of the way when speaking. If it is not filling up very much or constantly filing up all the way, adjust the speakers distance to the mic accordingly.

Note: The IR sensor is also built into the display, so you will want to point the screen toward the IR sensor on the receiver when pairing the transmitter. This will be easier with the gooseneck mic removed.
- 3. XLR Connector with Locking Ring:** Connect the included gooseneck microphone here, making sure to line up the groove on the mic plug with the groove in the connector. Twist on the locking ring to secure the mic.
- 4. Microphone Status Light:** This light on the microphone will illuminate when the transmitter is powered on and the mic is not muted. This can help listeners find the speaker more easily.
- 5. Battery Compartment:** Remove the battery cover to access the battery compartment. 2x AA 1.5V batteries are required to power the transmitter.

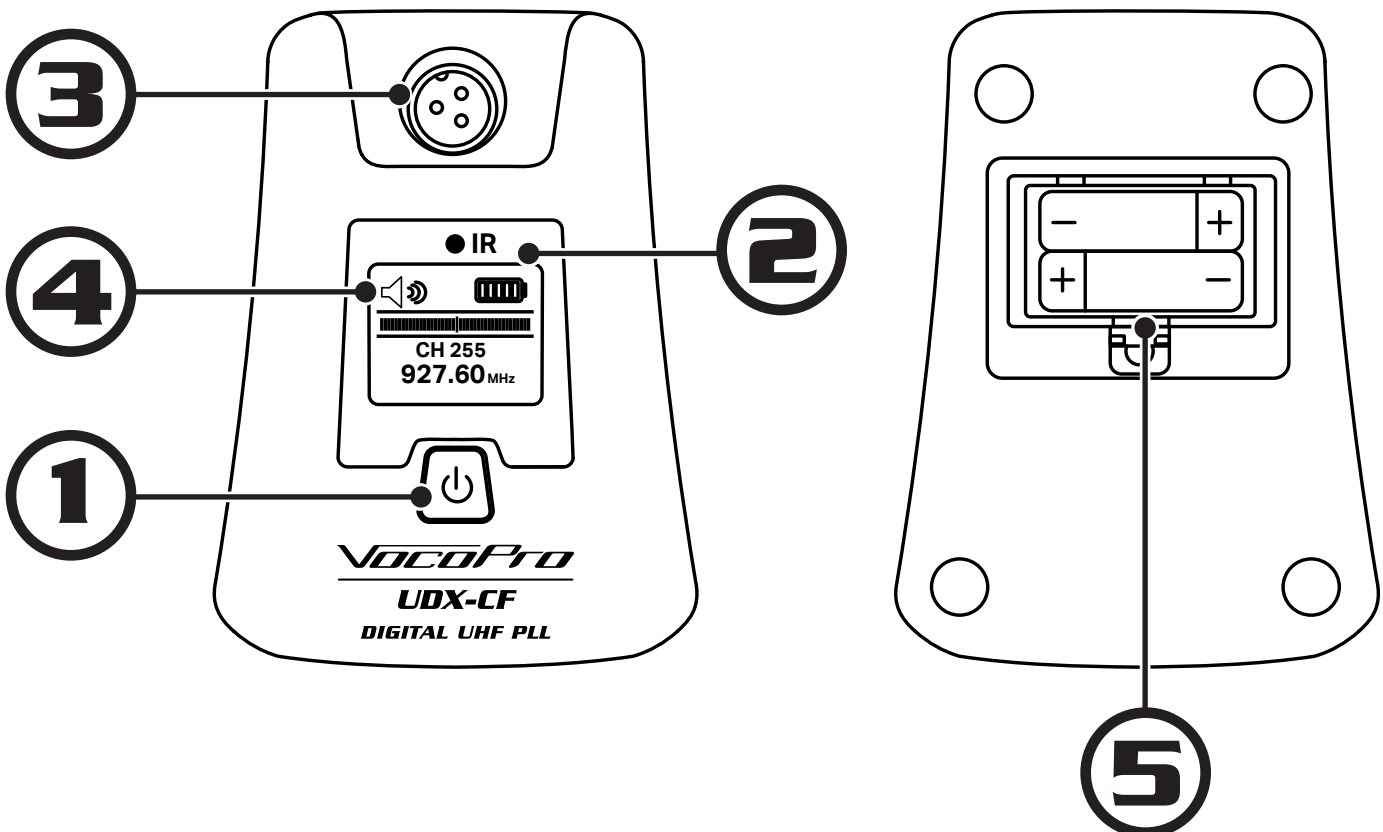

Functions & Descriptions

UDX-IT Transmitter

- 1. 15dB Pad:** When switched to the left, decreases input volume by 15dB to help control loud sound sources.
- 2. IR Emitter:** Face the emitter toward the IR Sensor on the receiver to sync frequencies.
- 3. Power Button:** Press and hold to power the transmitter ON and OFF.
- 4. Charge Port:** USB-C port for charging transmitter.
- 5. Gooseneck Microphone:** Use gooseneck to orient the microphone toward the sound source.
- 6. Clamp Screw:** Use this to secure the microphone to acoustic instruments (Brass, Percussion, etc.).

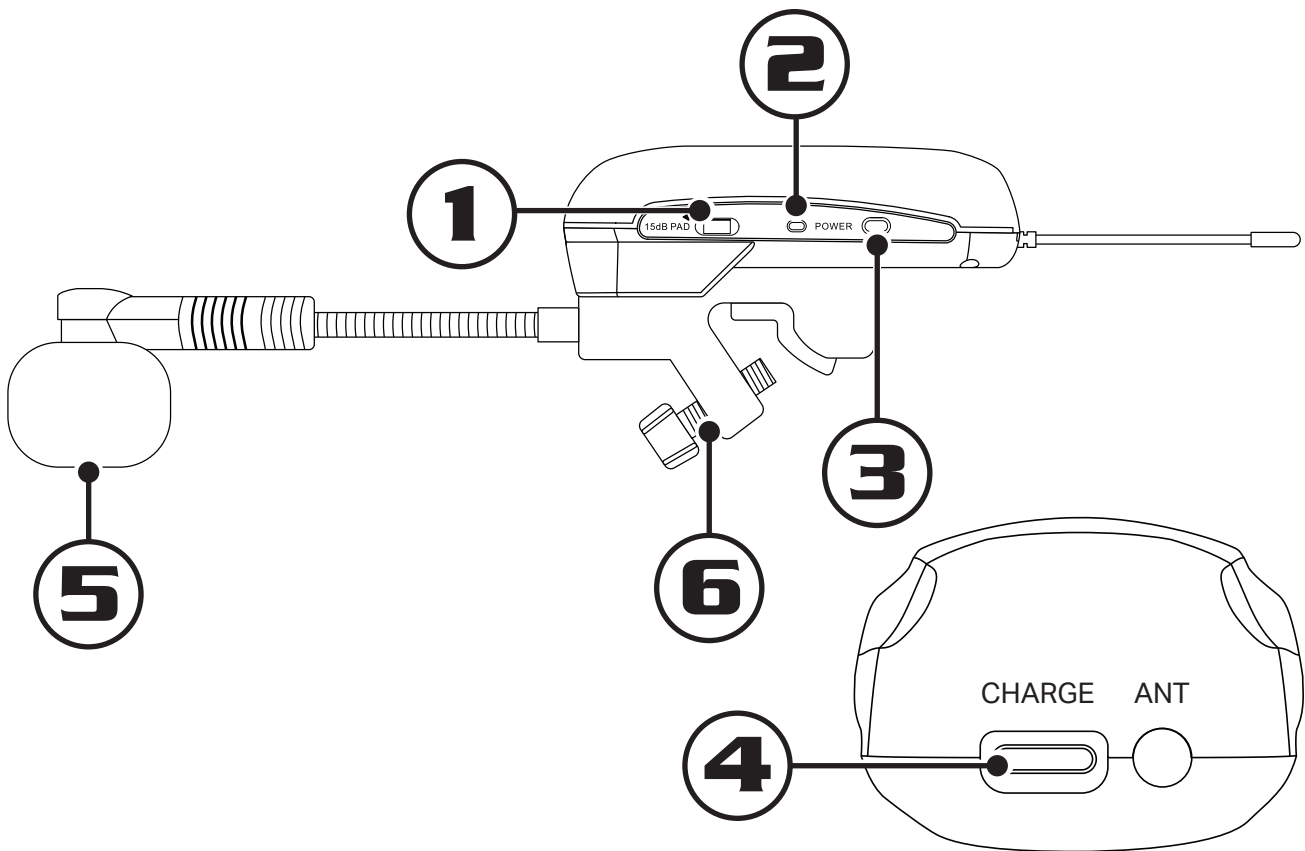

Features & Descriptions

UDX-GT3 Transmitter

- 1. 15dB Pad:** When switched to the left, decreases input volume by 15dB to help control loud sound sources.
- 2. IR Emitter:** Face the emitter toward the IR Sensor on the receiver to sync frequencies.
- 3. Power Button:** Press and hold to power the transmitter ON and OFF.
- 4. Charge Port:** USB-C port for charging transmitter.
- 5. 1/4" Plug:** 30° angled plug connects to instrument pick-up jack. (Guitar, Bass, Violin, Etc.)

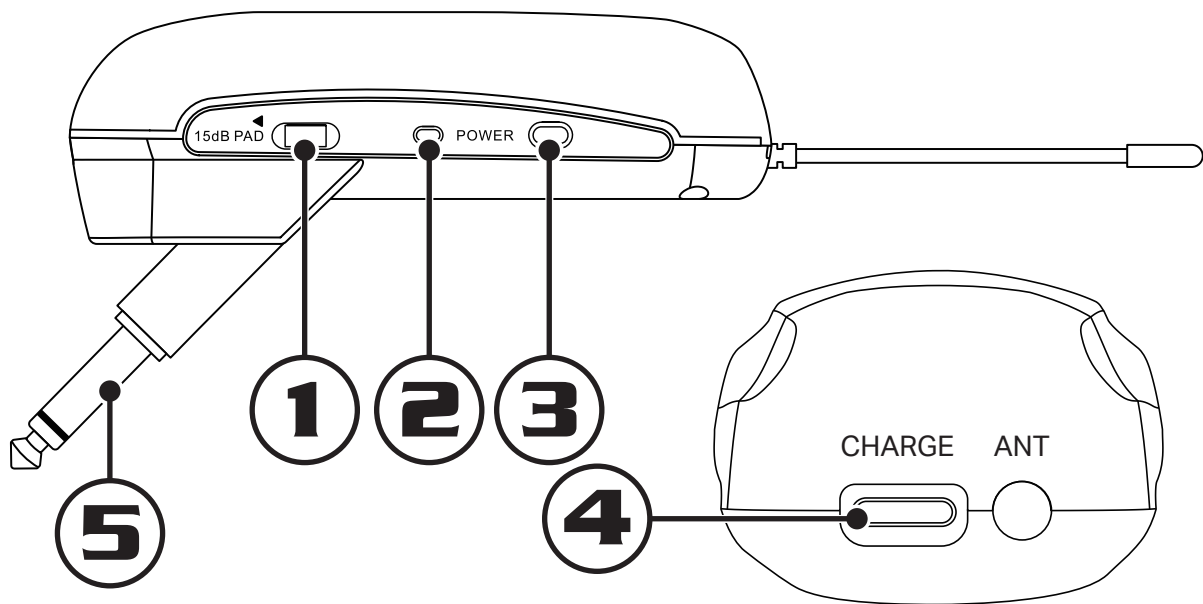

Features & Descriptions

UDX-GT9 Transmitter

1. **15dB Pad:** When switched to the left, decreases input volume by 15dB to help control loud sound sources.
2. **IR Emitter:** Face the emitter toward the IR Sensor on the receiver to sync frequencies.
3. **Power Button:** Press and hold to power the transmitter ON and OFF.
4. **Charge Port:** USB-C port for charging transmitter.
5. **1/4" Plug:** 90° angled plug connects to instrument pick-up jack. (Guitar, Bass, Violin, Etc.)

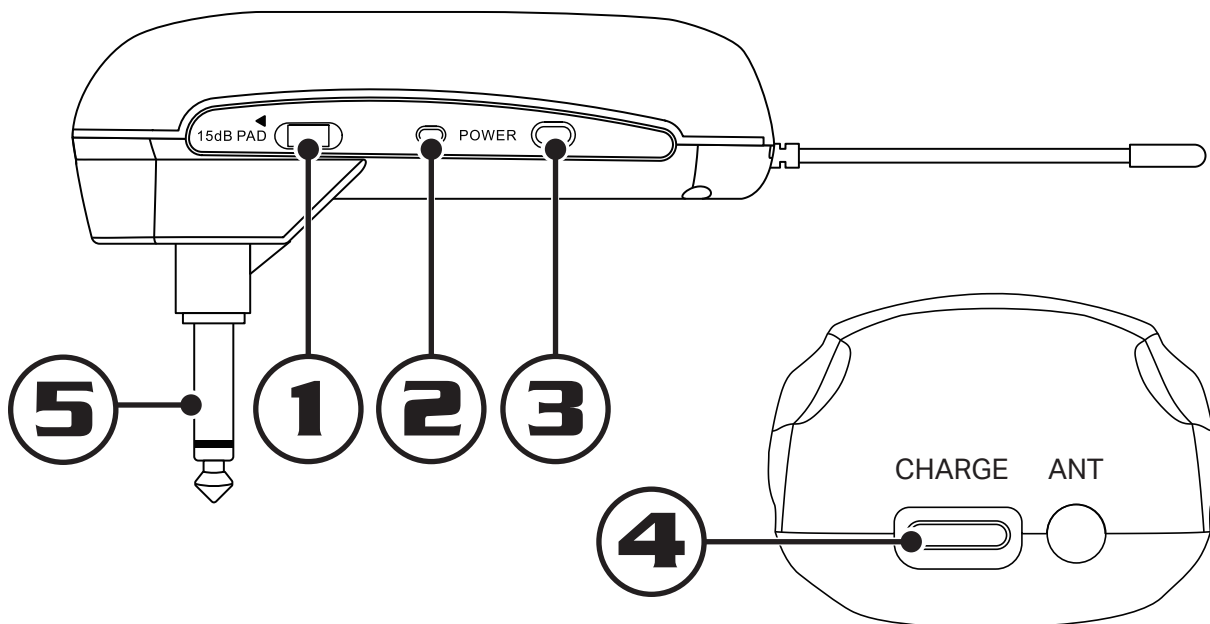

Getting Connected

1. Start by attaching the antenna to the receiver. The antenna will connect to the sockets on the back of the receiver labelled ANT-A and ANT-B. Screw the antenna on by twisting clockwise until they are tight.
2. Get the power adapter, connect the small end to the DC INPUT on the back of the receiver and plug the other end into a wall socket or power strip.

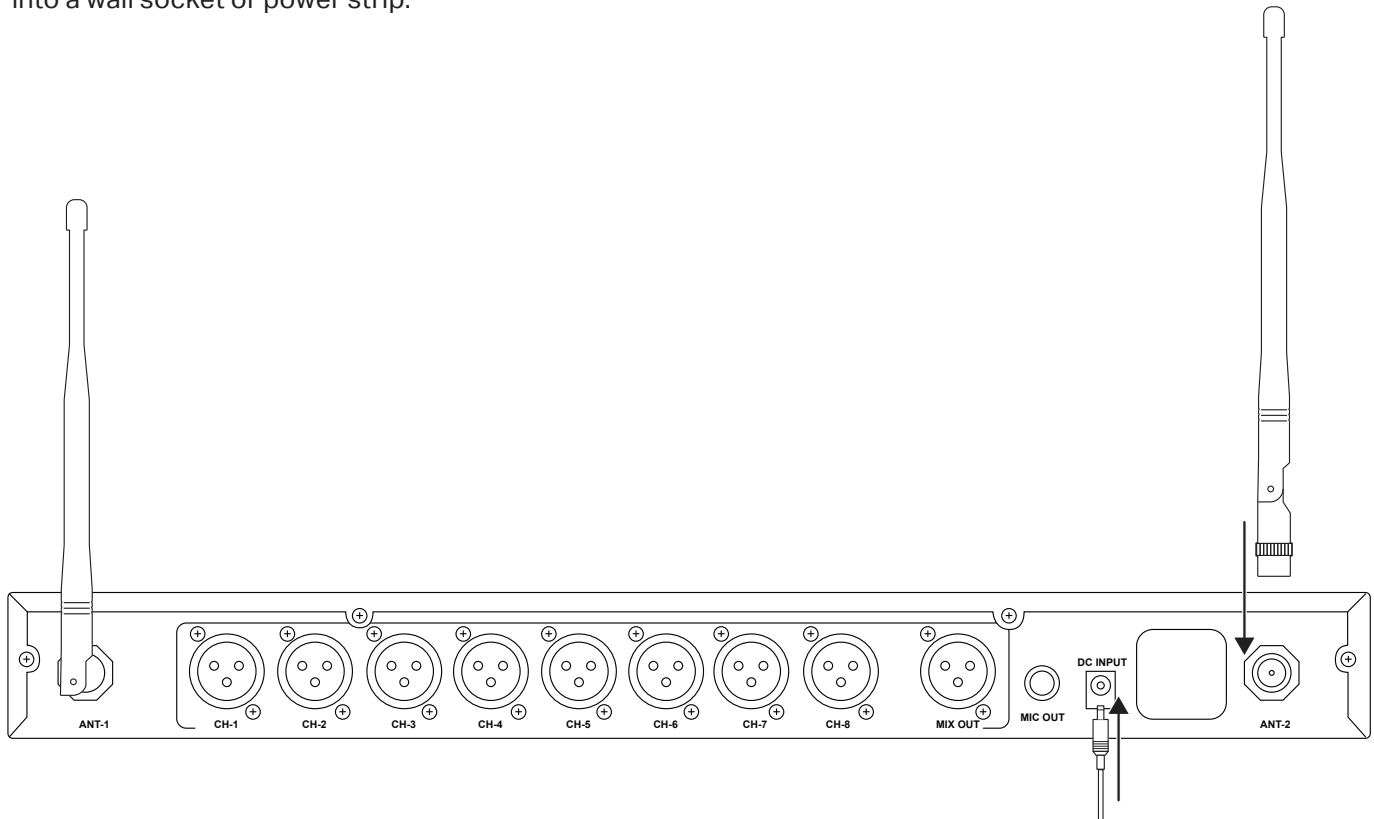

3. Connect the receiver to your mixer, amplifier, or powered speaker by using the audio outputs on the back of the receiver. There are 3 different options available on the UDX-OCTO receiver. Using option 1 or 2, you will have to use the volume controls on the UDX-OCTO receiver to control the volume for your mics. Using option 3 will allow you to set the initial volume output on the receiver, and then control the volume from your mixer after setup.

Option 1: Using the 1/4 inch Mixed Out

If the device you are connecting to only has 1/4 inch mic inputs, the easiest way to connect will be using the 1/4 inch mixed out. Using the included 1/4 inch audio cable, connect one end to the 1/4 inch MIX OUT on the receiver and connect the other end to the mic input on your device.

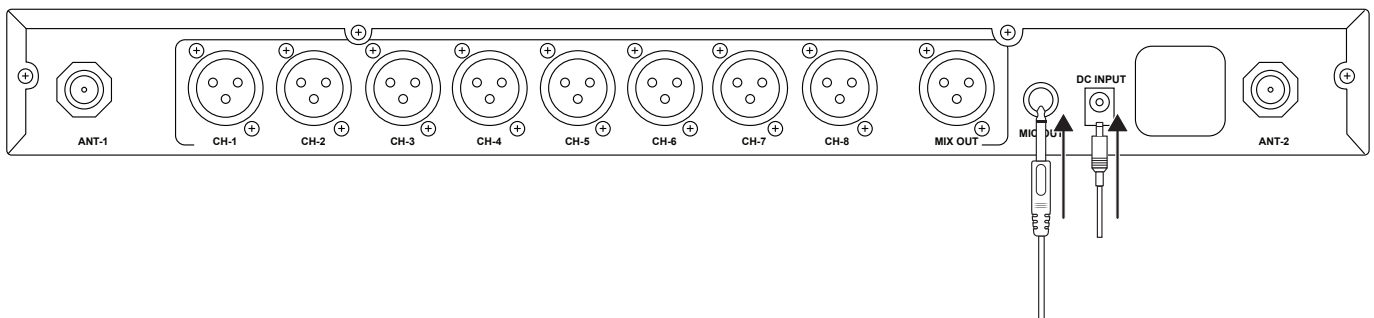

Getting Connected

Option 2: Using the XLR Mixed Out

If you are connecting to a device that has XLR mic inputs, but does not have enough inputs for all of your microphones to be connected individually, then you can use the XLR MIX OUT. Using a standard XLR cable (not included) connect the female end of the cable to the XLR MIX OUT on the receiver and connect the male end of the cable to the mic input on your device.

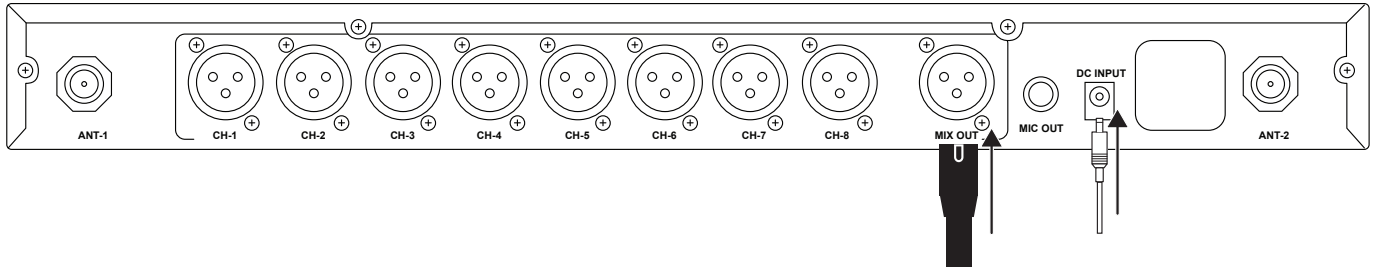

Option 3: Using the individual XLR Outputs

If you are connecting to a large mixer that has enough XLR mic inputs for all of your mics, you can use the individual XLR outputs. Use standard XLR cables (not included) to connect from each channel output that you are using to an input on your mixer.

Ex: If you are only using 6 transmitters on channels 1 thru 6 on the receiver, you do not need to connect all 8 outputs from the receiver, only channel 1 thru channel 6, only the channels you are using.

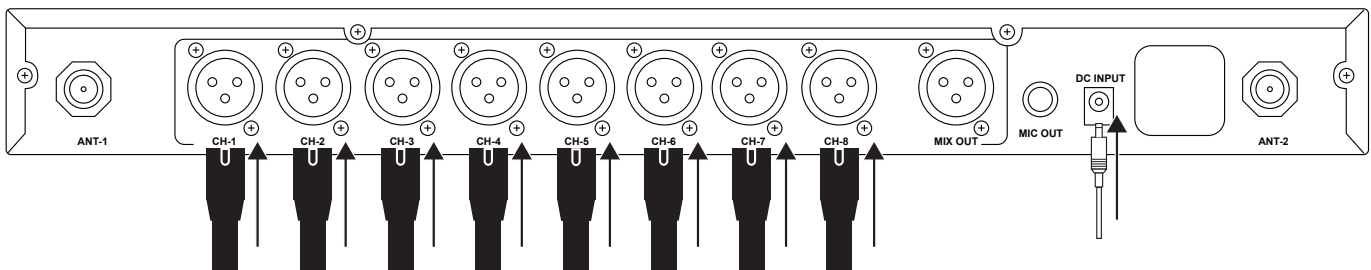

Syncing the Transmitters to the Receiver

Once we have the receiver hooked up, we can begin syncing the transmitters to the different channels on the receiver.

First, make sure all your transmitters have fresh, good quality batteries installed, and they are all powered on. Check the battery indicator on each transmitter.

Power on the receiver and wait a couple seconds for the system to start up.

Choose the channel you want to pair to, and hold down the IR Button on that channel until the IR light on the receiver begins flashing, about 3 seconds.

Hold the IR sensor on the transmitter up to the IR light on the receiver. For the UDX-HT handheld mic and the UDX-CF conference mic, the IR sensor is built into the display screen so you simply need to point the screen at the IR light. For the UDX-BP body pack, the IR sensor is under the battery cover so you will need to open the battery cover and point the front towards the IR light.

UDX-HT

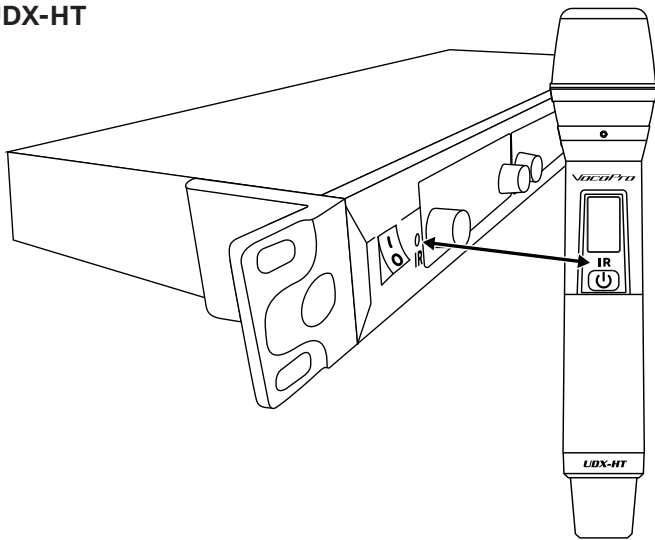

UDX-BP

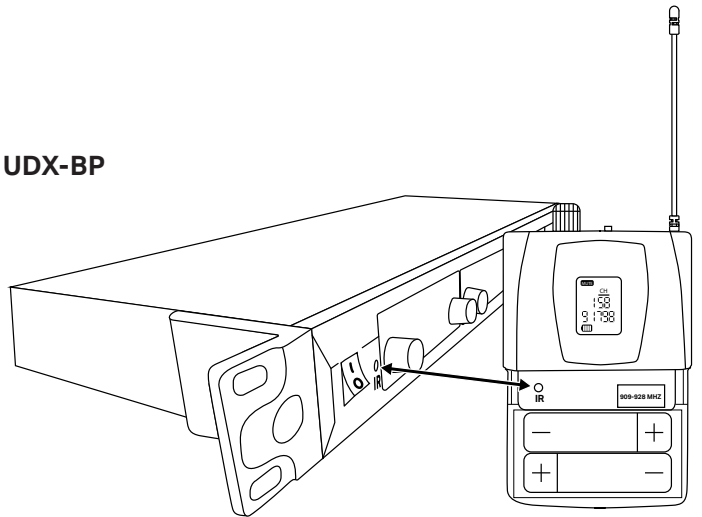

UDX-CF

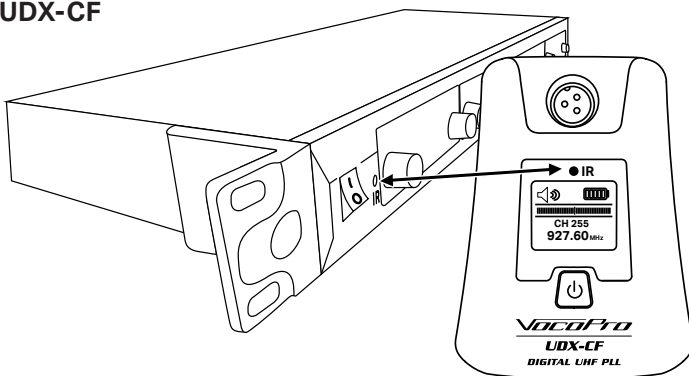

**UDX-GT9
UDX-GT3
UDX-IT**

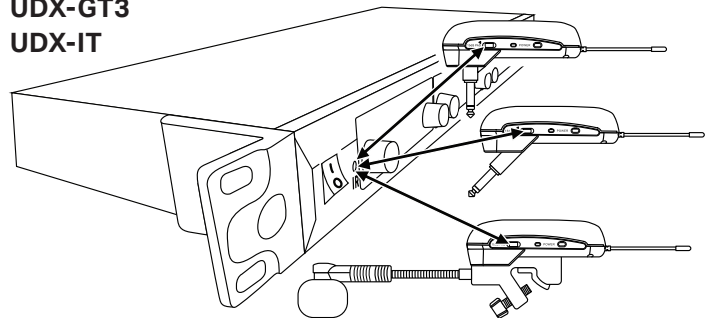

Syncing the Transmitters to the Receiver

Once the transmitter and receiver are in range of each other, it will only take a second for them to pair. You can check that they are paired by looking at the receiver's display. It should show that the RF meter is getting signal, the volume is not muted, you should be able to see the transmitter's battery life, and if you speak into the microphone the AF meter will show signal.

See the comparison between a channel that is synced to a transmitter, and one that is not.

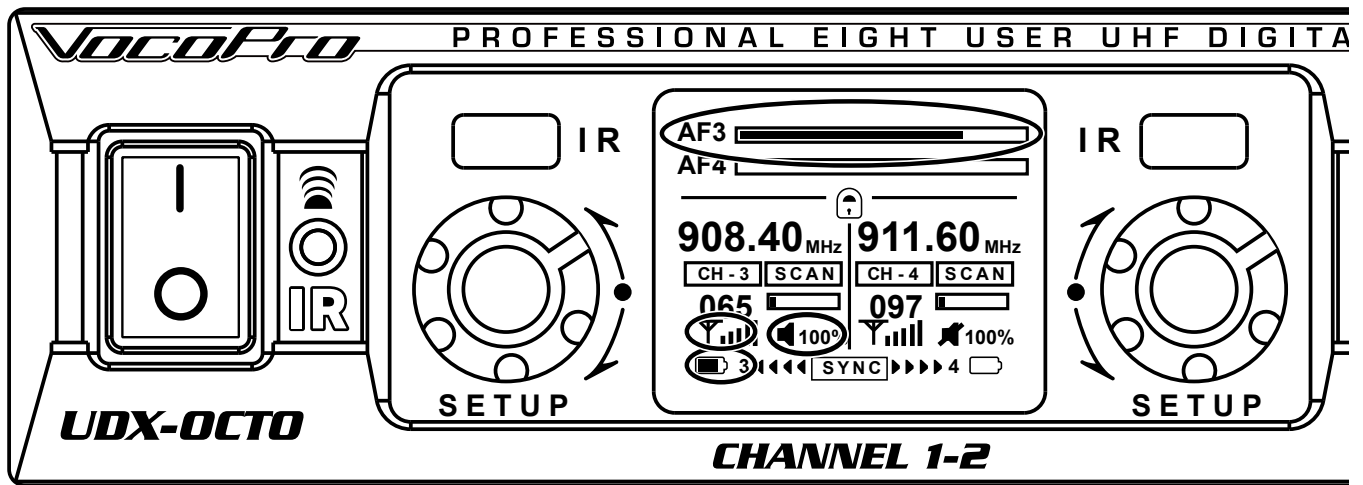

Please Note:

Once the IR button begins flashing, you have about 20 seconds to pair a transmitter. After you pair a transmitter, or if 20 seconds passes without pairing, the IR light will stop flashing. If you want to stop the pairing process before the 20 seconds are up, simply press any of the IR buttons and the light will stop flashing.

You will need to pair each transmitter individually, and to a separate channel. So as an example, let's say we have two UDX-HT handheld mics, one UDX-BP bodypack, and one UDX-CF conference mic, and we want to pair them to channels 1 thru 4 on the receiver. We'll need to hold down the IR button for channel 1 until the light flashes, then hold a handheld mic up to the receiver to pair. Then hold down the IR button for channel 2 and hold up the second handheld mic up to the receiver. Then hold down the IR button for channel 3 and hold up the bodypack to the receiver to pair. And finally hold down the IR button for channel 4 and hold up the conference transmitter base to pair.

Setting the Frequency on the Receiver

When you first turn on the UDX-OCTO receiver, channels 1 through 8 will all be set to different frequencies. So you can go ahead and sync your transmitters to each channel, following the instructions in the previous section, and you should be good to go.

The 900 MHz range is fairly open space so it is unlikely you will run into interference.

If you do experience any interference or audio cutting out issues, or if you already have some 900 MHz equipment you need to work around, you can change the frequencies for each channel on the receiver, and then re-sync your transmitters.

There are two methods to changing the frequency on each receiver channel:

Option 1: Scanning for open frequencies

Pick the channel you want to change. With the receiver powered on, push and hold the channel setup button until the screen is unlocked.

Push the setup button so you have SCAN on the right highlighted in blue, and there is no channel number on the left.

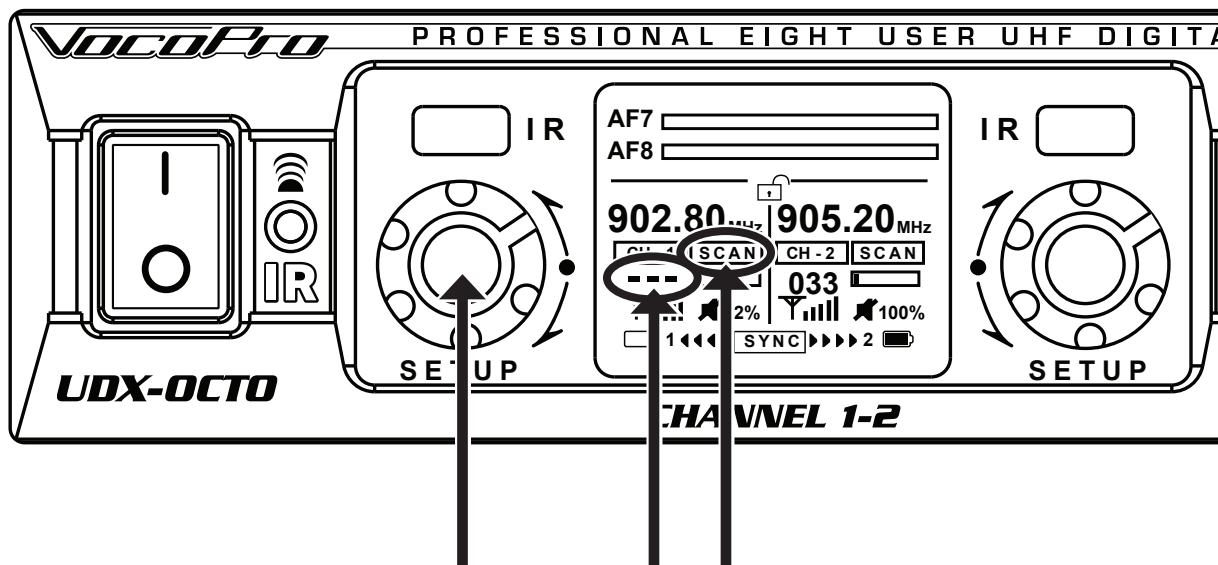

Now you can turn the knob and it will scan for the next available frequency, in increments of 0.1 MHz.

In Scan mode it will only allow you to select open frequencies.

For example, if you are scanning on channel 6, it will normally scan from 918.2 MHz up to 921.3 MHz. If you have something nearby transmitting at 920.1 MHz, then it will leave a large gap of frequencies in the middle to avoid that signal. You can turn the knob and scan up to around 919.0 MHz then it will jump up to around 921.3 MHz.

It leaves a large gap of open frequencies, and the 'edges' of that gap may fluctuate a bit because the frequency of the transmitters can fluctuate a little bit.

After using either method to set the frequency, you will need to re-sync the transmitter for that channel, using the instructions in the previous section.

Setting the Frequency on the Receiver

Option 2: Setting a specific frequency

Pick the channel you want to change. With the receiver powered on, push and hold the channel setup button until the screen is unlocked.

Push the setup button so you have CH-# on the left highlighted in blue, and there is a channel number below.

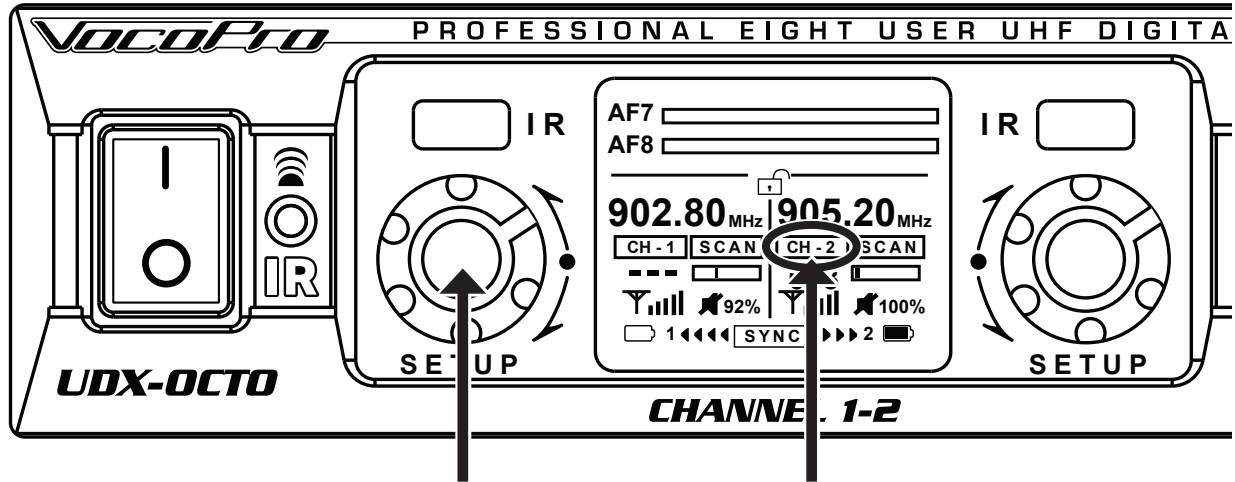

Now you can turn the knob to select any MHz frequency, in increments of 0.1 MHz, within the range for each channel.

After using either method to set the frequency, you will need to re-sync the transmitter for that channel, using the instructions in the previous section.

UDX-Dual Receiver

Receiver Channel	MHz Frequency Range	Channel Frequency Range
1	902 - 914.9	1 - 130
2	915 - 927.9	131 - 260

UDX-Octo Receiver

Receiver Channel	MHz Frequency Range	Channel Frequency Range
1	902 - 905.1	1 - 32
2	905.2 - 908.3	33 - 64
3	908.4 - 911.5	65 - 96
4	911.6 - 914.7	97 - 128
5	915 - 918.1	129 - 160
6	918.2 - 921.3	161 - 192
7	921.4 - 924.5	193 - 224
8	924.5 - 927.7	225 - 256

Specifications

Receiver

Adapter Rating:	12V-18V, $\geq 1.5A$
Operational Range:	~ 150 ft. w/ clear line of sight
SNR:	>90 dB
Frequency Response:	40Hz - 20KHz
Dynamic Range:	90dB

Handheld Transmitter

Capsule Type:	Dynamic
Battery:	2x AA 1.5V Alkaline
Run Time:	~ 8 hours

Bodypack Transmitter w/ Headset Mic

Capsule Type:	Condenser
Battery:	2x AA 1.5V Alkaline
Run Time:	~ 8 hours

Tabletop Transmitter w/ Gooseneck Mic

Capsule Type:	1/4" plug at 30° angle
Battery:	Internal Rechargeable
Run Time:	~8 hours

Instrument Transmitter w/ Microphone

Capsule Type:	Condenser
Battery:	Internal Rechargeable ~8 hours
Run Time:	

Guitar Transmitter 30°

Connector Type:	1/4" plug at 30° angle
Battery:	Internal Rechargeable
Run Time:	~8 hours

Guitar Transmitter 90°

Connector Type:	1/4" plug at 90° angle
Battery:	Internal Rechargeable
Run Time:	~8 hours

Troubleshooting

Equipment is not turning on:

For the Receiver:

- Make sure the power adapter is securely connected to the receiver and to your outlet or power strip.
- Check that the outlet or power strip is getting power, try plugging another device into the outlet.
- Ensure your power adapter is the original adapter or that its output rating fits within the range specified in the previous section.

For the Transmitters:

- Make sure you have new, good quality batteries, and that they are installed in the correct orientation.

Transmitter is not connecting to the receiver or is cutting out during use:

- Check to see if the frequency on the transmitter matches one of the channels on your receiver.
- Make sure the transmitter indicates good battery life remaining.
- Try scanning for a new open frequency on the receiver, and resyncing the transmitter.
- Make sure the antenna are securely connected to the back on the receiver and pointed upward.
- Ensure you are within range of the receiver and have clear line of sight between the transmitter and the receiver's antenna.

Transmitter is connected but I hear no audio:

- Make sure the transmitter is not muted, will read MUTE on the display if it is.
- Check the volume setting on the receiver channel. For the bodypack also check the volume knob.
- Speak into the mic and see if the AF meter on the receiver shows signal.
- Ensure the receiver is properly connected to your sound system, either through one of the MIX OUT connections or the corresponding individual CH-# output.
- Plug a wired microphone into your sound system to see if you are getting audio.

For the best sound reception:

- Make sure the transmitters have good battery life, if the indicator is low try new batteries to compare.
- Make sure the volume is turned up on the receiver, and on your sound system.
- When speaking into the microphone, make sure the mic pickup is within 1-2 inches of your mouth.
- For the handheld and conference mic, you want to be speaking into the top of the microphone as if you are speaking down the tube.
- For the headset mic, move the boom arm so the pickup is directly in front of your mouth, and rotate the boom arm so the pickup is pointing towards it. Remove the windscreen to see the pickup orientation.

LIMITED DOMESTIC WARRANTY

VOCOPRO WARRANTS ALL PRODUCTS PURCHASED IN U.S. AGAINST DEFECTS IN MATERIAL OR WORKMANSHIP FOR A PERIOD OF ONE YEAR FROM THE INITIAL DATE OF RETAIL PURCHASE FROM AN AUTHORIZED VOCOPRO DEALER, OR, ONE YEAR FROM THE DATE OF MANUFACTURE IF THE PROOF OF PURCHASE DATE IS NOT AVAILABLE. This limited warranty extends to all purchasers or owners of the product during the warranty period with the original retail purchase. VocoPro does not, however, warrant its products against any and all defects: 1) arising out of material or workmanship not provided or furnished by VocoPro, 2) resulting from abnormal use of the product or caused by use in violation of product instructions, 3) in products repaired or serviced by other service technicians other than authorized VocoPro repair facilities, 4) in products with removed or defaced serial numbers or 5) in components, parts or products expressly warranted by another manufacturer. VocoPro agrees to supply all parts and labor to repair or replace defects covered by this limited warranty with parts or products of original or improved design, at its option in each respect, if the defective product is shipped prior to the end of warranty period to any authorized VocoPro warranty repair facility in U.S., or to the VocoPro, in the original packaging or a replacement supplied by VocoPro, with all transportation costs and full insurance paid each way by the purchaser or owner.

LIMITED WARRANTY OUTSIDE THE U.S.

VOCOPRO PRODUCTS ARE WARRANTED ONLY IN THE COUNTRY WHERE PURCHASED THROUGH AN AUTHORIZED VOCOPRO DISTRIBUTOR IN THAT COUNTRY AGAINST DEFECTS IN MATERIAL OR WORKMANSHIP. THE SPECIFIC PERIOD OF THIS LIMITED WARRANTY SHALL BE THAT WHICH IS DESCRIBED TO THE ORIGINAL RETAIL PURCHASER BY THE AUTHORIZED DEALER OR DISTRIBUTOR AT THE TIME OF PURCHASE.

VocoPro does not, however, warrant its products against any and all defects: 1) arising out of material or workmanship not provided or furnished by VocoPro, 2) resulting from abnormal use of the product or caused by use in violation of product instructions, 3) in products repaired or serviced by other service technicians other than authorized VocoPro repair facilities, 4) in products with removed or defaced serial numbers or 5) in components, parts or products expressly warranted by another manufacturer. VocoPro agrees through the applicable authorized distributor, to repair or replace defects covered by this limited warranty with parts or products of original or improved design, at its option in each respect, if the defective product is shipped prior to end of warranty period to designated authorized VocoPro warranty repair facility in the country where purchased, or to the VocoPro Headquarter in the U.S., in the original packaging or a replacement supplied by VocoPro, with all transportation costs and full insurance paid each way by the purchaser or owner.

ALL REMEDIES AND THE MEASURE OF DAMAGES ARE LIMITED TO THE ABOVE SERVICES. IT IS POSSIBLE THAT ECONOMIC LOSS OR INJURY TO PERSON OR PROPERTY MAY RESULT FROM THE FAILURE OF THE PRODUCT; HOWEVER, EVEN IF VOCOPRO HAS BEEN ADVISED OF THIS POSSIBILITY, THIS LIMITED WARRANTY DOES NOT COVER ANY SUCH CONSEQUENTIAL OR INCIDENTAL DAMAGES. SOME STATES OR COUNTRIES DO NOT ALLOW THE LIMITATIONS OR EXCLUSIONS OF INCIDENTAL OR CONSEQUENTIAL DAMAGES, SO THE ABOVE LIMITATION MAY NOT APPLY TO YOU.

ANY AND ALL WARRANTIES, EXPRESSED OR IMPLIED, ARISING BY LAW, COURSE OF DEALING, COURSE OF PERFORMANCE, USAGE OF TRADE, OR OTHERWISE, INCLUDING BUT NOT LIMITED TO IMPLIED WARRANTIES OF MERCHANTABILITY AND FITNESS FOR A PARTICULAR PURPOSE, ARE LIMITED TO A PERIOD OF ONE YEAR FROM EITHER THE DATE OF ORIGINAL RETAIL PURCHASE OR, IN THE EVENT OF NO PROOF OF PURCHASE DATE IS AVAILABLE, THE DATE OF MANUFACTURE. SOME STATES OR COUNTRIES DO NOT ALLOW LIMITATIONS ON HOW LONG AN IMPLIED WARRANTY LASTS, SO THE ABOVE LIMITATIONS MAY NOT APPLY TO YOU.

THE LIMITED WARRANTY GIVES YOU SPECIFIC LEGAL RIGHTS, AND YOU MAY ALSO HAVE OTHER RIGHTS THAT VARY FROM STATE TO STATE, COUNTRY TO COUNTRY.

LIMITED DOMESTIC WARRANTY

From:

Place
Stamp
Here

To: VOCOPRO HEADQUARTER
1728 CURTISS COURT
LA VERNE, CA 91750

WARRANTY PROCEDURE

TO VALIDATE YOUR WARRANTY: Fill out the attached warranty card, being sure to include the model and serial number of the unit since this is how warranty cards are tracked. If your VocoPro product was purchased in the U.S., mail the completed card directly to VocoPro within 10 days of the date of purchase. If you purchased the product outside the U.S. you must file your warranty registration card with the distributor in that country. It is advised that you keep your bill of sale as proof of purchase, should any difficulties arise concerning the registration of the warranty card.

WARRANTY REGISTRATION is made and tracked by MODEL AND SERIAL NUMBER ONLY, not by the purchaser's or owner's name. Therefore any warranty correspondence or inquiries MUST include the model and serial number of the product in question. Be sure to fill in the model and serial number in the space provided below and keep this portion of the warranty card in a safe place for future reference.

WARRANTY SERVICE MUST BE PERFORMED ONLY BY AN AUTHORIZED VOCOPRO SERVICE FACILITY LOCATED IN THE COUNTRY WHERE THE UNIT WAS PURCHASED, OR AT THE VOCOPRO HEADQUARTERS IN THE U.S. It is recommended that advance notice be given to the repair facility to avoid needless shipment in case the problem can be solved over the phone. UNAUTHORIZED SERVICE PERFORMED WILL VOID ANY EXISTING FACTORY WARRANTY ON THAT PRODUCT.

FACTORY SERVICE: If you wish your product to be serviced at the factory, it must be shipped FULLY INSURED, IN THE ORIGINAL PACKING OR EQUIVALENT. This warranty will NOT cover repairs on products damaged through improper packaging. If possible, avoid sending products through the mail. Be sure to include in the package:

1. Complete return shipping address (P.O. Box number are NOT acceptable).
2. A detailed description of any problems experienced, including the make and model numbers of any other equipment in the system.

Repaired products will be returned freight C.O.D. unless sufficient return shipment funds are included with the unit.

Products sent to the factory from outside the U.S. MUST include return freight funds, and the sender is fully responsible for all, customs procedures, duties, tariffs and deposits.

RECORD THE MODEL AND SERIAL NUMBER BELOW AND RETAIN THIS PORTION OF THE WARRANTY CARD FOR YOUR FILES:

MODEL

SERIAL NUMBER

DATE OF PURCHASE

PLACE OF PURCHASE

LIMITED DOMESTIC WARRANTY

Detach this portion and mail it to the factory

MODEL _____ MANUFACTURE DATE _____ SERIAL NO. _____

OWNER'S NAME _____ ADDRESS _____

CITY _____ STATE _____ ZIP _____

The following information is appreciated, but not required:

Dealer's name and address: _____

What other products and/or product changes would you like to see Manufactured? _____

Any other comments: _____

Our Team is Here to Help



Please do not return to the retailer if you are having a technical issue operating or connecting the unit. If you need additional help, have questions, or need support with your VocoPro product contact us:

Toll Free: 800-678-5348
TEL: 909-593-8893
FAX: 909-593-8890

Email Tech Support at:
techsupport@vocopro.com

